

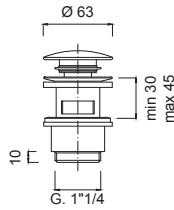



# ARTICOLI VARI

5102L



**Scarico per lavabo Up&Down 1"1/4.**  
Basin drain 1"1/4 Up&Down.  
Vidage lavabo Up&Down 1"1/4.  
Ablaufgarnitur Up&Down 1"1/4.  
Desague automatico Up&Down 1"1/4.  
Слив для умывальника Up&Down 1"1/4

Articolo	Note	CROMO	BO - NO	NKO	BROP - GF - CRN	O - OSP
5102L						

5105L

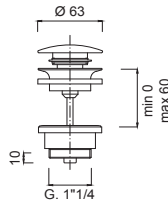

**Scarico per lavabo Up&Down 1"1/4.**  
Basin drain 1"1/4 Up&Down.  
Vidage lavabo Up&Down 1"1/4.  
Ablaufgarnitur Up&Down 1"1/4.  
Desague automatico Up&Down 1"1/4.  
Слив для умывальника Up&Down 1"1/4

Articolo	Note	CROMO	BO - NO	NKO	BROP - GF - CRN	O - OSP
5105L						

5112

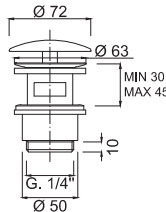

**Scarico per lavabo 1"1/4, scarico libero**  
Basin drain 1"1/4, free flow.  
Vidage lavabo 1"1/4, toujours ouvert.  
Ablaufgarnitur 1"1/4, immer geöffnet.  
Desagüe automatico 1"1/4, descarga libre.  
Заглушка для раковины с соединением 1"1/4, свободный слив

Articolo	Note	CROMO	BO - NO	NKO	BROP - GF - CRN	O - OSP
5112						

5115

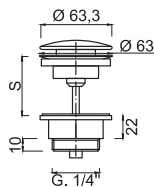

**Scarico per lavabo 1"1/4, scarico libero**  
Basin drain 1"1/4, free flow.  
Vidage lavabo 1"1/4, toujours ouvert.  
Ablaufgarnitur 1"1/4, immer geöffnet.  
Desagüe automatico 1"1/4, descarga libre.  
Заглушка для раковины с соединением 1"1/4, свободный слив

Articolo	Note	CROMO	BO - NO	NKO	BROP - GF - CRN	O - OSP
5115						

5103L

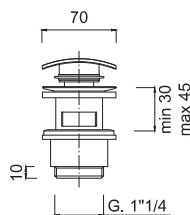

**Scarico per lavabo Up&Down 1"1/4 quadro**  
Basin drain 1"1/4 Up&Down.  
Vidage lavabo Up&Down 1"1/4.  
Ablaufgarnitur Up&Down 1"1/4.  
Desague automatico Up&Down 1"1/4.  
Слив для умывальника Up&Down 1"1/4

Articolo	Note	CROMO	BO - NO	NKO	BROP - GF - CRN	O - OSP
5103L						

5003

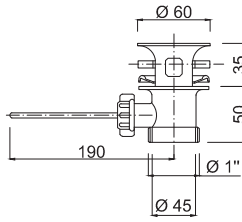

**Scarico lusso 1".**

Luxury 1" pop-up waste.  
Vidage automatique 1" lux  
Automatischer Ablauf 1" lux  
Desagüe lujo 1".  
Слив люкс 1"

Articolo	Note	CROMO	BO - NO	NKO	BROP - GF - CRN	O
5300						

5004

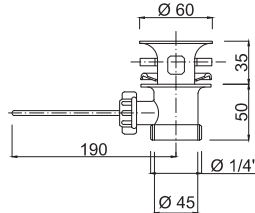

**Scarico lusso 1"1/4.**

Luxury 1"1/4 pop-up waste.  
Vidage automatique 1"1/4 lux  
Automatischer Ablauf 1"1/4 lux  
Desagüe lujo 1"1/4.  
Слив люкс 1"1/4

Articolo	Note	CROMO	BO - NO	NKO	BROP - GF - CRN	O
5004						

5005L



**Astina per scarico 1" mm 300.**

Rod with ball mm 300.  
Tige avec sphère pour vidage automatique mm 300.  
Stange für automatischen Ablauf mit Kugel mm 300.  
Varilla para desagüe mm 300.  
Штанга для слива 300 мм

Articolo	Note	CROMO	BO - NO	NKO	BROP - GF - CRN	O
5005L						

5006



**Tappo per scarico 1" Ø 37.**

Plug for drain 1" Ø 37  
Bouchon pour vidage 1" Ø 37  
Verschluß für Ablaufgarnitur von 1" Ø 37  
tapón para desagüe 1" Ø 37.  
Затычка для слива 1" Ø 37.

Articolo	Note	CROMO	BO - NO	NKO	BROP - GF - CRN	O
5006						

5007



**Tappo per scarico 1"1/4 Ø 40.**

Plug for drain 1"1/4 Ø 40  
Bouchon pour vidage 1"1/4 Ø 40  
Verschluß für Ablaufgarnitur von 1"1/4 Ø 40  
tapón para desagüe 1"1/4 Ø 40.  
Затычка для слива 1"1/4 Ø 40.

Articolo	Note	CROMO	BO - NO	NKO	BROP - GF - CRN	O
5007						

5109PL

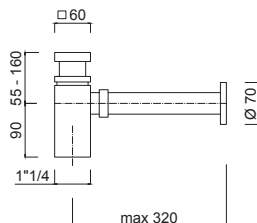

**Sifone per lavabo 1"1/4 quadro**

Trap for basin 1"1/4.  
Siphon lavabo 1"1/4.  
Geruchsverschluss 1"1/4.  
Sifón para lavabo 1"1/4.  
Сифон для умывальника 1"1/4 квадратный

Articolo	Note	CROMO	BO - NO	NKO	BROP - GF - CRN	O
5109PL						

5109L

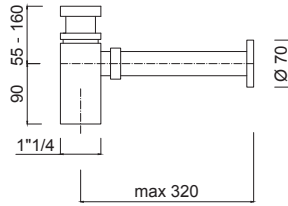

**Sifone per Lavabo 1"1/4.**  
Trap for basin 1"1/4 .  
Siphon lavabo 1"1/4.  
Geruchsverschluss 1"1/4.  
Sifón para lavabo 1"1/4.  
Сифон для умывальника 1"1/4

Articolo	Note	CROMO	BO - NO	NKO	BROP - GF - CRN	O - OSP
5109L						

5009

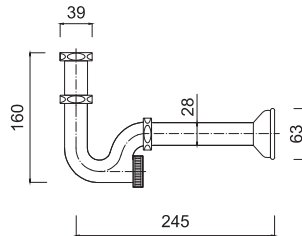

**Sifone per Lavabo 1"1/4.**  
Trap for basin 1"1/4 .  
Siphon lavabo 1"1/4.  
Messing Rohrsiphon 1"1/4 für Waschtisch  
Sifón para lavabo 1"1/4.  
Сифон для раковины 1"1/4

Articolo	Note	CROMO	BO - NO	NKO	BR	O
5009						

5009B

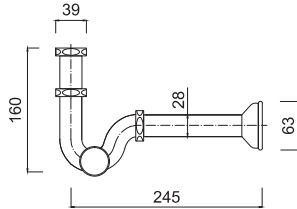

**Sifone per bidet 1"1/4.**  
Brass basin trap 1"1/4.  
Siphon bidet laiton 1"1/4.  
Messing Rohrsiphon 1"1/4 für Bidet  
Sifón bidet en laiton 1"1/4.  
Сифон для умывальника из латуны 1"1/4.

Articolo	Note	CROMO	BO - NO	NKO	BR	O
5009B						

5011

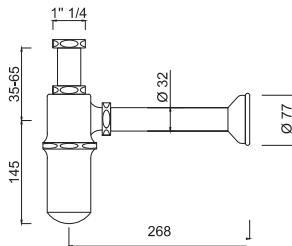
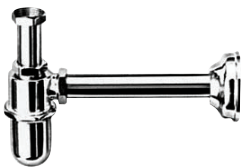

**Sifone 1" 1/4 a bottiglia.**  
Bottle trap for basin 1" 1/4.  
Siphon bouteille pour lavabo 1"1/4.  
Tassensiphon 1" 1/4 für Waschtisch.  
Sifón botella para lavabo 1"1/4.  
Сифон бутылка 1" 1/4.

Articolo	Note	CROMO	BO - NO	NKO	BR	O
5011						

3264L

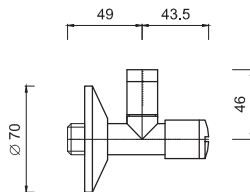

**Rubinetto sottolavabo con filterstop.**  
Under-sink valve with filterstop.  
Coude sous lavabo avec filterstop.  
Eckventile mit Filter.  
Llave de paso para lavabo con filterstop.  
Смеситель под раковину с filterstop

Articolo	Note	CROMO	BO - NO	NKO	BROP - GF - CRN	O - OSP
3264L						

3063

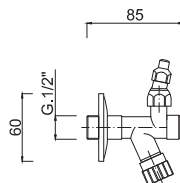

**Rubinetto con filtro con snodo.**  
Tap with filter with articulated joint.  
Robinet d'arret avec filtre et coude  
Eckventil mit Filter  
Llave de regulaciòn con filtro  
Смеситель с фильтром и шарниром

Articolo	Note	CROMO	BO - NO	NKO	BR	O
3063						

3064

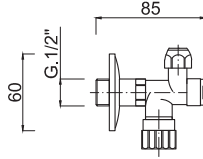

**Rubinetto con filtro.**  
Tap with filter.  
Robinet d'arret avec filter  
Eckventil mit Filter  
Grifo con filtro.  
Смеситель с фильтром

Articolo	Note	CROMO	BO - NO	NKO	BROP - GF - CRN	O
3064						

3070



**Tappo copriforo Ø43.**  
Hole cover Ø43.  
Cache-trou Ø43.  
Lochdeckelverschluss Ø43.  
Tapon sobreagujer Ø43.  
Затычка для отверстия Ø43.

Articolo	Note	CROMO	BO - NO	NKO	BROP - GF - CRN	O
3070						

5167

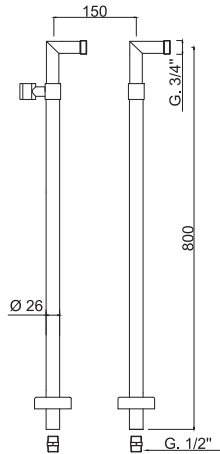
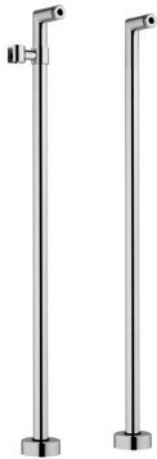

**Coppia piantoni a pavimento per gruppi vasca.**  
Pair floor external set for bathtub set.  
Couple jonctions verticales pour mélangeur bain  
Paarbindung für äußere Badewannengruppe  
Copia columna en suelo para grupo bañera.  
Пара напольных стоек для смесителя для ванны

Articolo	Note	CROMO	BO - NO	NKO	BROP - GF - CRN	O
5167						

5164

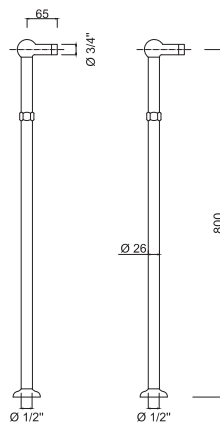

**Coppia piantoni a pavimento per gruppi vasca.**  
Pair floor external set for bathtub set.  
Couple jonctions verticales pour mélangeur bain  
Paarbindung für äußere Badewannengruppe  
Copia columna en suelo para grupo bañera.  
Пара напольных стоек для смесителя для ванны

Articolo	Note	CROMO	NO	BR	O
5164					

5014

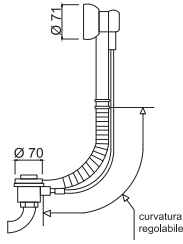

**Colonna vasca.**

Automatic pop-up waste for bathtub  
Vidage automatique à colonne pour baignoire avec alimentation  
Automatischer Säulenablauf für Badewannen  
Columna bañera.  
Стойка для ванны

Articolo	Note	CROMO	BO - NO	NKO	BROP - GF - CRN	O
5014						

5018



**Squadretta Ø 12 con rosone e niple mm 150x250.**

Square Ø 12 with rosette and nipple mm 150x250.  
équerre pour rondelle Ø 12 mm 150x250.  
Befestigungswinkel  
Escuadrita Ø 12 para placa arandela e niple mm 150x250.  
Крепеж Ø 12 с розеткой и соединителем мм 150x250

Articolo	Note	CROMO	BO - NO	NKO	BR	O
5018						

0128



**Tubetto Ø 10 cm 35 con cartella e calotta.**

Ø 10 cm 35 connection pipe with casing and cap.  
Tuyans Ø 10 cm 35 avec bordure  
Gebogene Schläuche Ø 10 cm 35 mit Rand  
Tubito Ø 10 cm 35 con revestimiento y casquete.  
Трубка Ø 10 см 35 с креплением и колпаком

Articolo	Note	CROMO	BO - NO	NKO	BR	O
0128						

0128/M



**Tubetto Ø 10 cm 35 attacco m10**

Copper tube Ø 10, 35 cm, m10 connection  
Tube cuivre Ø 10, 35 cm, raccord m10  
Kupferrohr Ø 10, 35 cm, M10-Anschluss  
Tubo de cobre Ø 10, 35 cm, conexión m10  
Медная трубка Ø 10, 35 см, соединение M10

Articolo	Note	CROMO	BO - NO	NKO	BR	O
0128/M						

5052-R25



**Canotto WC Ø 32 mm 250 con rosone.**

Ø 32 mm 250 tube with flange for WC  
Tuyan Ø 32 mm 250 avec rosace pour WC  
Schlauch Ø 32 mm 250 mit Rosette für WC  
Tubo descarga WC Ø 32 mm 250 con placa arandela  
Трубка WC Ø 32 мм 250 с розеткой

**Altre misure disponibili su richiesta.**

Other sizes available on request.  
Другие размеры доступны по запросу.  
Andere Größen auf Anfrage erhältlich

Articolo	Note	CROMO	BO - NO	NKO	BROP - GF - CRN	O
5052-R25	25cm					
5052-R30	30cm					
5052-R45	45cm					

5052-C25



**Canotto WC Ø 32, mm 250, con cartella**

WC drain pipe Ø 32, 250 mm, with folder  
Tuyau d'évacuation WC Ø 32, 250 mm, avec pliage  
WC-Ablaufrohr Ø 32, 250 mm, mit Faltung  
Tubo de desagüe WC Ø 32, 250 mm, con plegado  
Сливная труба для унитаза Ø 32, 250 мм, с откидной

**Altre misure disponibili su richiesta.**

Other sizes available on request.  
Другие размеры доступны по запросу.  
Andere Größen auf Anfrage erhältlich

Articolo	Note	CROMO	BO - NO	NKO	BR	O
5052-C25	25cm					
5052-C30	30cm					
5052-C45	45cm					

5B40



**Rubinetto incasso cappuccio chiuso 1/2".**  
1/2" close cap built-in tap.  
Robinet à encaissement come fermé 1/2"  
Einbauhahn mit 1/2" verschloßenem Käppchen  
Grifo para empotrar con pequeño capucho cerrado 1/2".  
Встраиваемый смеситель с закрытым колпаком 1/2"

Articolo	Note	CROMO	BO - NO	NKO	BROP - GF - CRN	O
5B40						

5082-18

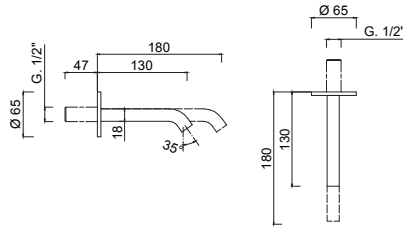

**Bocca lavabo muro MyFuture**  
MyFuture wall-mounted sink spout  
Bec de lavabo mural MyFuture  
MyFuture Wandauslauf für Waschbecken  
Caño para lavabo de pared MyFuture  
MyFuture настенный излив для раковины

Articolo	Note	CROMO	BO - NO	NKO	BROP - GF - CRN	O - OSP
5082-18	180mm					
5082-13	130mm					

MR3222-20

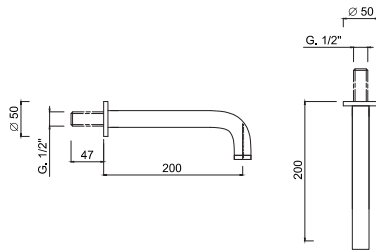

**Bocca lavabo muro MyRing**  
MyRing wall-mounted sink spout  
Bec de lavabo mural MyRing  
MyRing Wandauslauf für Waschbecken  
Caño para lavabo de pared MyRing  
MyRing настенный излив для раковины

Articolo	Note	CROMO	BO - NO	NKO	BROP - GF - CRN	O
MR3222-20						
MR3222-20DL	LUX					

5080-20

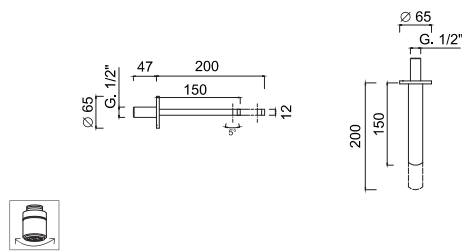

**Bocca mm 200, con rosone Surf.**  
Spout mm 200, with rosette Surf.  
Bec mural mm 200, avec rosace Surf.  
Wandauslauf mm 200, mit Rosette Surf.  
Caño mural mm 200, con florón Surf.  
Излив длина 200 мм с розеткой Surf.

Articolo	Note	CROMO	BO - NO	NKO	BROP - GF - CRN	O
5080-20	200mm					
5080-15	150mm					
5080-20DL	200mm LUX					
5080-15DL	150mm LUX					

5081-20

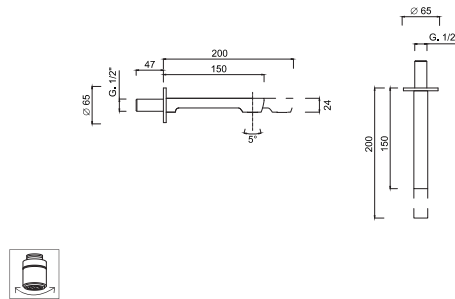

**Bocca lavabo muro EGO**  
EGO wall-mounted sink spout  
Bec de lavabo mural EGO  
EGO Wandauslauf für Waschbecken  
Caño para lavabo de pared EGO  
EGO настенный излив для раковины

Articolo	Note	CROMO	BO - NO	NKO	BROP - GF - CRN	O
5081-20	200mm					
5081-15	150mm					

5085-20

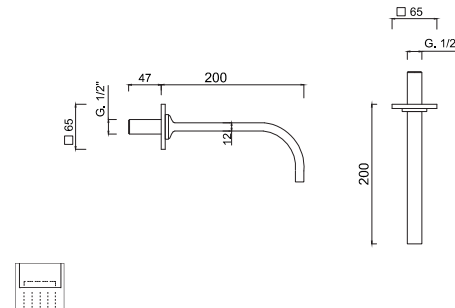

**Bocca lavabo muro PABLLOLUX B3**  
PABLLOLUX B3 wall-mounted sink spout  
Bec de lavabo mural PABLLOLUX B3  
PABLLOLUX B3 Wandauslauf für Waschbecken  
Caño para lavabo de pared PABLLOLUX B3  
PABLLOLUX B3 настенный излив для раковины

Articolo	Note	CROMO	BO - NO	NKO	BROP - GF - CRN	O
5085-20	200mm					



**5084-20**

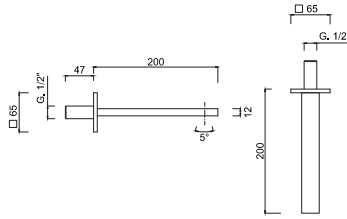

**Bocca lavabo muro PABLOLUX B4**  
PABLOLUX B4 wall-mounted sink spout  
Bec de lavabo mural PABLOLUX B4  
PABLOLUX B4 Wandauslauf für Waschbecken  
Caño para lavabo de pared PABLOLUX B4  
PABLOLUX B4 настенный излив для раковины

Articolo	Note	CROMO	BO - NO	NKO	BROP - GF - CRN	O
5084-20						

**3222-25**

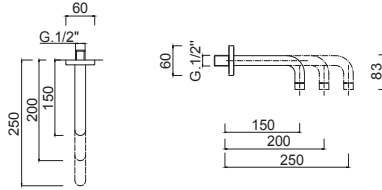

**Bocca Ø 24 mm 250 con rosone fil. 1/2" M.**  
Ø 24 mm 250 spout with rosette fil. 1/2" M.  
Bouche Ø 24 mm 250 avec rondelle 1/2" M.  
Auslauf Ø 24 mm 250 mit Scheibe 1/2" M.  
Boca Ø 24 mm 250 con placa a rendela fil. 1/2" M.  
Излив Ø 24 мм 250 с розеткой fil. 1/2" M.

Articolo	Note	CROMO	BO - NO	NKO	BROP - GF - CRN	O
3222-25	250mm					
3222-20	200mm					
3222-15	150mm					

**5083-20**

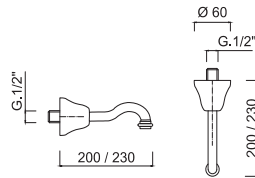

**Bocca con rosone.**  
Spout with rosette.  
Bec mural avec rosace.  
Wandauslauf mit Rosette.  
Caño mural con florón.  
Излив с розеткой

Articolo	Note	CROMO	BR	O		
5083-20	200mm					
5083-15	150mm					

**1764**

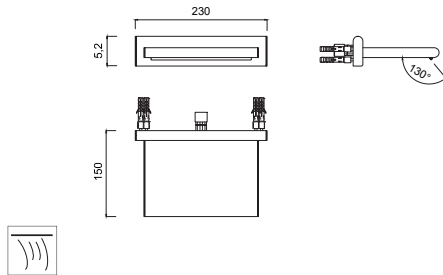

**Bocca cascata a muro per vasca.**  
Wall waterfall spout for bathtub  
Bec cascade mural pour baignoire  
Wand-Wasserfallauslauf für Badewanne  
Caño cascada de pared para bañera  
Настенный излив-водопад для ванны

Articolo	Note	CROMO	BO - NO	NKO	BROP - GF - CRN	O
1764						

**5125**

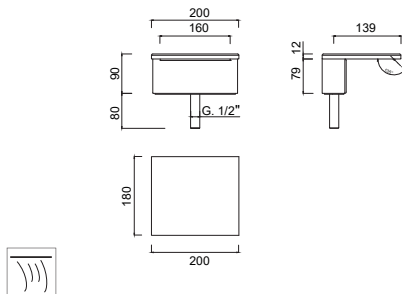

**Bocca bordo vasca.**  
Boarder bath set spout.  
Bec bord baignoire  
Wanneneinlauf für Wannenrandbatterie  
Boca borde bañera.  
Излив для установки на борту ванны

Articolo	Note	CROMO	BO - NO	NKO	BROP - GF - CRN	O
5125						

**3095**

**Prolunga incasso 5920 - 5921 - 5916, mm.280, con cover.**  
Built-in extension for 5920-5921-5916 - mm 280 with cover  
Rallonge à encaissement pour 5920-5921-5916 - mm 280 avec plaque  
Verlängerung für Unterputz 5920-5921-5916 - mm 280 mit Abdeckung  
Extensión empotrable para 5920-5921-5916 - mm 280 con tapa  
Встроенный удлинитель для 5920-5921-5916 - мм 280 с крышкой

Articolo	Note	CROMO	BO - NO	NKO	BROP - GF - CRN	O
3095						

3096

**Prolunga incasso 5290 - 5284, mm. 280, con cover.**  
*Built-in extension for 5290-5284- mm 280 with cover*  
*Rallonge à encaissement pour 5290-5284 - mm 280 avec placque*  
*Verlängerung für Unterputz 5290-5284 - mm 280 mit Abdeckung*  
*Extensión empotrable para 5290-5284 - mm 280 con tapa*  
*Встроенный удлинитель для 5290-5284 - мм 280 с крышкой*

Articolo	Note	CROMO	BO - NO	NKO	BROP - GF - CRN	O
3096						

3190

**Prolunga per BOX 5297, mm. 280, con cover.**  
*Extension for BOX 5297, mm. 280 with cover*  
*Rallonge pour BOX 5297, mm. 280 avec placque*  
*Verlängerung für BOX 5297, mm. 280 mit Abdeckung*  
*Extensión para BOX 5297, mm. 280 con tapa*  
*Удлинитель для BOX 5297, мм. 280 с крышкой*

Articolo	Note	CROMO	BO - NO	NKO	BROP - GF - CRN	O
3190						

3097

**Prolunga incasso 5287, con pulsante a rotazione, mm.280, con cover.**  
*Built-in extension for 5287, with rotating button, 280 mm, with cover.*  
*Rallonge à encaissement pour 5287, avec bouton rotatif, 280 mm, avec placque*  
*Verlängerung für Unerputz 5287, mit Drehknopf, 280 mm, mit Abdeckung.*  
*Extensión empotrable para 5287, con botón giratorio, 280 mm, con tapa.*  
*Встроенный удлинитель для 5287, с вращающейся кнопкой, 280 мм, с крышкой.*

Articolo	Note	CROMO	BO - NO	NKO	BROP - GF - CRN	O
3097						

3098

**Prolunga per Box 5285-5286, mm.250, con cover.**  
*Extension for Box 5285-5286, mm. 250, with cover*  
*Rallonge pour Box 5285-5286, mm. 250, avec placque*  
*Verlängerung für Box 5285-5286, mm. 250, mit Abdeckung*  
*Extensión para Box 5285-5286, mm. 250, con tapa*  
*Удлинитель для ящика 5285-5286, мм. 250, с крышкой*

Articolo	Note	CROMO	BO - NO	NKO	BROP - GF - CRN	O
3098						

3192

**Prolunga per incasso 5301 - 5302, mm.280, con cover**  
*Prolunga per incasso 5301 - 5302, mm.280, con cover*  
*Built-in extension for 5301 - 5302, mm 280 with cover*  
*Rallonge à encaissement pour 5301-5302 - mm 280 avec placque*  
*Verlängerung für Unterputz 5301-5302 - mm 280 mit Abdeckung*  
*Extensión empotrable para 5301-5302 - mm 280 con tapa*  
*Встроенный удлинитель для 5301-5302 - мм 280 с крышкой*

Articolo	Note	CROMO	BO - NO	NKO	BROP - GF - CRN	O
3192						

3194

**Prolunga per incasso 5304 - 5305, mm.280, con cover**  
*Built-in extension for 5304 - 5305, mm 280 with cover*  
*Rallonge à encaissement pour 5304-5305 - mm 280 avec placque*  
*Verlängerung für Unterputz 5304-5305 - mm 280 mit Abdeckung*  
*Extensión empotrable para 5304-5305 - mm 280 con tapa*  
*Встроенный удлинитель для 5304-5305 - мм 280 с крышкой*

Articolo	Note	CROMO	BO - NO	NKO	BROP - GF - CRN	O
3194						

0095



**Prolunga per rubinetto incasso. Specificare per quale articolo.**  
*Extension hose for built-in tap. Specify for which item.*  
*Rallonge pour robinet à encastrer. Indiquer pour quelle la référence.*  
*Verlängerung für Serie Unterputzhahn. Für welche Artikelnummer nennen.*  
*Alargador para grifo para empotrar. Especifici quen la referencia.*  
*Удлинитель для встроенного смесителя. Уточнить, для какого артикула.*

Articolo	Note	CROMO	BO - NO	NKO	BROP - GF - CRN	O
0095						

3290-MYF



**Parte esterna per deviatore MyFuture.**  
*Parte esterna per deviatore MyFuture.*  
*External part for MyFuture diverter.*  
*Partie externe pour inverseur MyFuture.*  
*Außenteil für MyFuture-Umsteller.*  
*Parte externa para desviador MyFuture.*  
*Внешняя часть переключателя MyFuture.*

Articolo	Note	CROMO	BO - NO	NKO	BROP - GF - CRN	O - OSP
3290-MYF						

0041-12



**Corpo deviatore 3 vie (1 entrata + 2 uscite).**  
*3-way diverter body (1 inlet + 2 outlets).*  
*Corps inverseur 3 voies (1 entrée + 2 sorties).*  
*3-Wege-Umstellerkörper (1 Eingang + 2 Ausgänge).*  
*Cuerpo desviador de 3 vías (1 entrada + 2 salidas).*  
*Корпус трехходового переключателя (1 вход + 2 выхода).*

Articolo	Note	CROMO				
0041-12	1+2					
0041-13	1+3					

5190

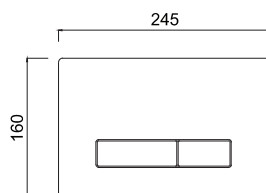

**Comando per cassetta scarico WC compatibile modelli Geberit (verificare compatibilità con Ufficio Tecnico).**  
*Control Plate for WC flush cistern compatible with Geberit models (check compatibility with Technical Department)*  
*Plaque de contrôle pour réservoir de chasse d'eau compatible avec les modèles Geberit (vérifier la compatibilité avec le service technique).*  
*Steuerplatte für WC-Spülkasten kompatibel mit Geberit-Modellen (Kompatibilität mit der technischen Abteilung prüfen).*  
*Mando para cisterna de descarga de inodoro compatible con modelos Geberit (consultar compatibilidad con Departamento Técnico).*  
*Контрольная пластина для бачка унитаза, совместимая с моделями Geberit (совместимость уточняйте в техническом отделе).*

Articolo	Note	CROMO	BO - NO	NKO	BROP - GF - CRN	O
5190						

